

SPECIFICATION FOR APPROVAL

※This is a RoHS and REACH compliant product whose related documents are available on request.
 ※Graphic is only for dimensionally application.

1. PART NUMBER IDENTIFICATION

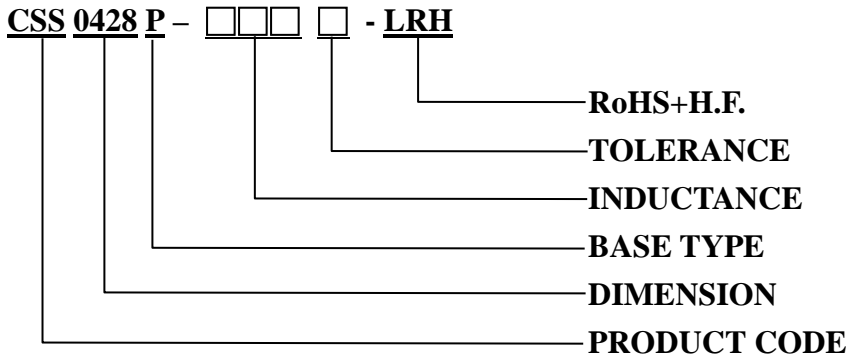

2. MECHANICAL DIMENSION

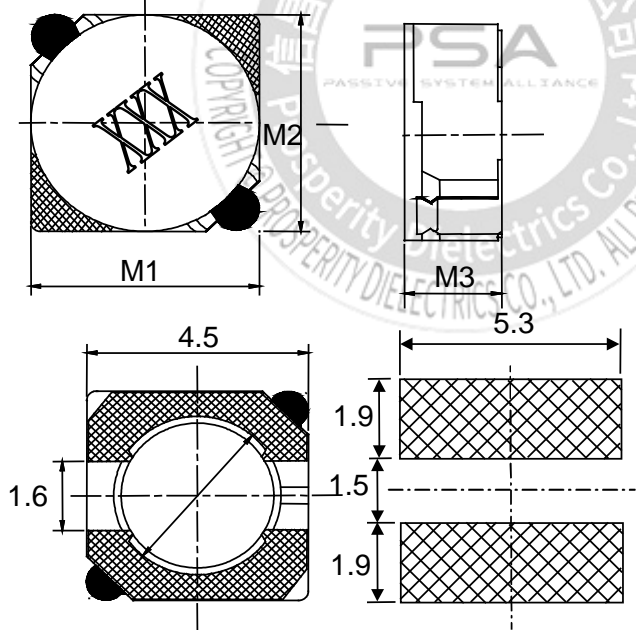

UNIT : mm

	DIM.	TOL.
M1	4.7	±0.3
M2	4.7	±0.3
M3	3.0	MAX.

Recommended Patterns

SPECIFICATION FOR APPROVAL

3. ELECTRICAL SPECIFICATION

Part number	Marking	Inductance (uH)	Test Frequency (KHz)	DC Resistance (mOHM) MAX.	Rated Current (A)
CSS0428P-1R2N-LRH	1R2	1.2	100	23.6	2.56
CSS0428P-1R8N-LRH	1R8	1.8	100	27.5	2.20
CSS0428P-2R2N-LRH	2R2	2.2	100	31.3	2.04
CSS0428P-2R7N-LRH	2R7	2.7	100	43.3	1.60
CSS0428P-3R3N-LRH	3R3	3.3	100	49.2	1.57
CSS0428P-3R9N-LRH	3R9	3.9	100	64.8	1.44
CSS0428P-4R7N-LRH	4R7	4.7	100	72.0	1.32
CSS0428P-5R6N-LRH	5R6	5.6	100	100.9	1.17
CSS0428P-6R8N-LRH	6R8	6.8	100	108.9	1.12
CSS0428P-8R2N-LRH	8R2	8.2	100	117.5	1.04
CSS0428P-100N-LRH	100	10	100	128.3	1.00
CSS0428P-120N-LRH	120	12	100	131.6	0.84
CSS0428P-150N-LRH	150	15	100	149.0	0.76
CSS0428P-180N-LRH	180	18	100	166.0	0.72
CSS0428P-220N-LRH	220	22	100	235.0	0.70
CSS0428P-270N-LRH	270	27	100	261.0	0.58
CSS0428P-330N-LRH	330	33	100	331.3	0.56
CSS0428P-390N-LRH	390	39	100	383.7	0.50
CSS0428P-470N-LRH	470	47	100	587.0	0.48
CSS0428P-560N-LRH	560	56	100	624.5	0.41
CSS0428P-680N-LRH	680	68	100	699.0	0.35
CSS0428P-820N-LRH	820	82	100	914.8	0.32
CSS0428P-101N-LRH	101	100	100	1020	0.29
CSS0428P-121N-LRH	121	120	100	1270	0.27
CSS0428P-151N-LRH	151	150	100	1350	0.24
CSS0428P-181N-LRH	181	180	100	1540	0.22

TEST INSTRUMENT: Chroma3302,1320.16502.

1.Tolerance : N : $\pm 30\%$

2.Inductance drops no more than 35 % of initial value at rated current ,temperature rises $\Delta t < 40^{\circ}\text{C}$.

2.Operating temperature range: -25°C to $+125^{\circ}\text{C}$.

3.Storage temperature range: -25°C to $+85^{\circ}\text{C}$.

4.MSL : LEVEL 1