

信昌電子陶瓷股份有限公司

Prosperity Dielectrics Co., Ltd.

No.566-1, Gaoshi Rd., Lujhu, Yangmei Dist., Taoyuan City 32668, Taiwan, R.O.C.

Tel. : +886-3-4753355

Fax : +886-3-4854959

SPECIFICATION FOR APPROVAL

DATE :

CUSTOMER :

PART NAME :

Metal Strip Type Halogen Free Current Sensing Resistors

CUSTOMER'S DWG. NO. :

CUSTOMER'S PART NO. :

PDC PART NO. :

FMF SERIES APPROVED

DESCRIPTION. :

| ACTION               | "V" | CUSTOMER'S SIGNATURE | NOTE |
|----------------------|-----|----------------------|------|
| RESULT               |     |                      |      |
| FULL APPROVED        |     |                      |      |
| CONDITIONAL APPROVED |     |                      |      |
| REJECTED             |     |                      |      |

| OUR ACTION  | SIGNATURE   |
|-------------|-------------|
| PREPARED By | Jenny Tseng |
| CHECKED By  | Tony Chou   |
| APPROVED By | Byron Tsai  |

|                                      |
|--------------------------------------|
| CUSTOMER SIGNATURE FOR<br>ACCEPTANCE |
|--------------------------------------|

## Contents.

| Descriptions                                  | Pages |
|-----------------------------------------------|-------|
| 01. Features                                  | 2     |
| 02. Applications                              | 2     |
| 03. Dimension and construction                | 2     |
| 04. Power Derating Curve                      | 2     |
| 05. Rating                                    | 3-4   |
| 06. Part Number                               | 5     |
| 07. Marking / Soldering                       | 5-6   |
| 08. Reliability Performance                   | 7-9   |
| 09. Packing Information                       | 10-11 |
| 10. Storage / Handling                        | 11    |
| ※ Appendix (Max. Current &. Overload Current) | 12-13 |

### 1. Features

- High power rating and low TCR.
- Low resistance and high precision (1%). Low EMF type  $\leq 3\mu V/^\circ C$ .
- Low inductance less than 1.0nH available please contact factory.
- Excellent reliability and suitable cost.
- Suitable for lead free soldering.
- High precision trimming implement.
- RoHS compliant & Halogen Free.

### 2. Applications

- Switching model power supply.
- Battery pack.
- Notebook, Tablet PC
- Test Instrument.
- Power Amplifier.

### 3. Dimension and Construction

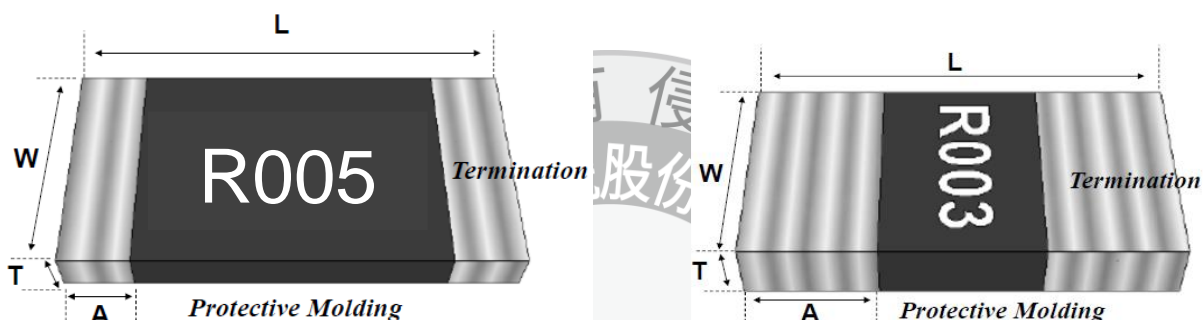

| Item     | Protective Molding | Resistive Element | Internal Terminal | External Terminal |
|----------|--------------------|-------------------|-------------------|-------------------|
| Material | Resin              | Alloy Metal       | Copper            | Solder            |

Unit : mm

| FMF                | L         | W         | T         | A         |
|--------------------|-----------|-----------|-----------|-----------|
| 1206 1~2mΩ         | 3.20±0.20 | 1.70±0.20 | 0.70±0.20 | 1.10±0.25 |
| 1206 0 &. 3~30mΩ   | 3.10±0.20 | 1.65±0.20 | 0.60±0.20 | 0.60±0.20 |
| 2512 0 &. 4~100mΩ  | 6.20±0.20 | 3.25±0.20 | 0.60±0.20 | 0.80±0.20 |
| 2512 1~3 mΩ        | 6.40±0.20 | 3.25±0.20 | 0.75±0.20 | 2.00±0.20 |
| 2512 3W 4~100mΩ    | 6.20±0.20 | 3.25±0.20 | 0.65±0.20 | 0.80±0.20 |
| 2512 3W 2~3 mΩ     | 6.40±0.20 | 3.25±0.20 | 0.75±0.20 | 2.00±0.20 |
| 2512 3W 1mΩ        | 6.40±0.20 | 3.25±0.20 | 0.80±0.20 | 2.00±0.20 |
| 2512 3W 0.5~0.75mΩ | 6.30±0.20 | 3.25±0.20 | 0.80±0.20 | 2.25±0.20 |

### 4. Power Derating Curve

Operating Temperature Range: -55 to +170°C

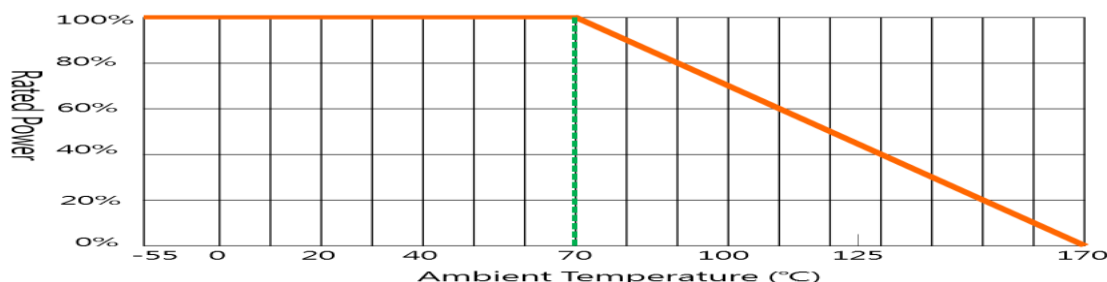

## 5. Rating

Table A.

| Rating<br>Type              | Tolerance (%)                                   | Rating 70°C (W) | Max. Working Current (Voltage)* | Max. Overload Current (Voltage)* | Alloy Type                       | Temperature coefficient of Resistance (ppm/°C)** | Resistance (mΩ) & Jumper(0)****                                                            |
|-----------------------------|-------------------------------------------------|-----------------|---------------------------------|----------------------------------|----------------------------------|--------------------------------------------------|--------------------------------------------------------------------------------------------|
| <b>FMF06</b><br><b>1206</b> | <b>±1%(F)</b><br><b>±2%(G)</b><br><b>±5%(J)</b> | <b>0.5</b>      | 22.4A<br>(111mV)                | 50.0A<br>(250mV)                 | Low EMF                          | <b>±75</b>                                       | <b>1,2</b>                                                                                 |
|                             |                                                 |                 |                                 |                                  |                                  | <b>±70</b>                                       | <b>3,4,5,6,7,8,9,<br/>10,12,15,20,25</b>                                                   |
|                             |                                                 |                 | Standard                        | <b>±50</b>                       | <b>5,10,15,18<br/>20,25,30</b>   |                                                  |                                                                                            |
|                             |                                                 | <b>1</b>        | 31.6A<br>(158mV)                | 70.7A<br>(354mV)                 | Low EMF                          | <b>±75</b>                                       | <b>1,2</b>                                                                                 |
|                             |                                                 |                 |                                 |                                  |                                  | <b>±70</b>                                       | <b>3,4,5,6,7,8,9,<br/>10,12,15,20,25</b>                                                   |
|                             |                                                 |                 | Standard                        | <b>±50</b>                       | <b>0,5,10,15<br/>18,20,25,30</b> |                                                  |                                                                                            |
| <b>FMF25</b><br><b>2512</b> | <b>±0.5% (D)***</b>                             | <b>1</b>        | 31.6A<br>(158mV)                | 70.7A<br>(354mV)                 | Low EMF                          | <b>±70</b>                                       | <b>1,2,2.5,3,4,5<br/>10,15,20,25</b>                                                       |
|                             |                                                 |                 |                                 |                                  |                                  | <b>±50</b>                                       | <b>3,4,5,6,7,8,9,10<br/>12,15,18,20,22,25<br/>30,33,35,40,50,60<br/>70,75,80,100</b>       |
|                             | <b>±1%(F)</b><br><b>±2%(G)</b><br><b>±5%(J)</b> | <b>2</b>        | 44.7A<br>(224mV)                | 100A<br>(500mV)                  | Low EMF                          | <b>±70</b>                                       | <b>1,2,2.5,3,4,5<br/>10,15,20,25</b>                                                       |
|                             |                                                 |                 |                                 |                                  |                                  | <b>±50</b>                                       | <b>0,3,4,5,6,7,8,9,10<br/>12,15,18,20,22,25<br/>30,33,35,40,50,60<br/>70,75,80,100,150</b> |
|                             |                                                 |                 | 25.8A<br>(548mV)                | 57.7A<br>(1225mV)                | Standard                         | <b>±50</b>                                       | <b>0,3,4,5,6,7,8,9,10<br/>12,15,18,20,22,25<br/>30,33,35,40,50,60<br/>70,75,80,100,150</b> |
|                             |                                                 |                 |                                 |                                  |                                  | <b>±50</b>                                       | <b>0,3,4,5,6,7,8,9,10<br/>12,15,18,20,22,25<br/>30,33,35,40,50,60<br/>70,75,80,100,150</b> |

Note:

- (i)  $E = \sqrt{P \cdot R}$  or Max. Working Voltage whichever is lower.
- (ii) E : Working Voltage(V) , P : Rated Power (W) , R : Resistance Value(Ω)
- (iii) Please keep the surface temperature do not exceed 105°C when operating.
- (iv) \* : Related number are depend on specific items only. \*\* : TCR Hot (+25~+155°C).  
\*\*\* : ±0.5% available resistance with underline. Ex. 10
- (v) \*\*\*\* : Detail Jumper(0Ω) information please refer table C
- (vi) R-value might be variance depend on soldering conditions and please consider this influence before use milli-ohm resistors, and strongly suggest use the recommend solder pad to design your circuits.
- (vii) Max. working & Max. overload current details please refer Annex. 1.

Table B.

| Rating<br>Type        | Tolerance (%)           | Rating 70°C (W)                     | Max. Working Current (Voltage)* | Max. Overload Current (Voltage)* | Alloy Type | Temperature coefficient of Resistance (ppm/°C)** | Resistance (mΩ)                                                 |
|-----------------------|-------------------------|-------------------------------------|---------------------------------|----------------------------------|------------|--------------------------------------------------|-----------------------------------------------------------------|
| <b>FMF25<br/>2512</b> | <b>±0.5%<br/>(D)***</b> | <b>3</b>                            | <b>77.5A</b><br>(47mV)          | <b>173.2A</b><br>(106mV)         | Low EMF    | <b>±70</b>                                       | <b>0.5,0.75</b>                                                 |
|                       |                         |                                     | <b>54.8A</b><br>(245mV)         | <b>122.5A</b><br>(548mV)         |            | <b>±70</b>                                       | <b>1,2,2.5,3,4,5<br/>6,7,8,9,10</b>                             |
|                       |                         | <b>±1%(F)<br/>±2%(G)<br/>±5%(J)</b> | <b>3</b>                        | <b>24.5A</b><br>(812mV)          |            | <b>54.8A</b><br>(1817mV)                         | Standard                                                        |
|                       |                         |                                     |                                 |                                  |            | <b>±50</b>                                       | <b>12,14,15,16,18,20<br/>25,30,33,35,40,50<br/>60,75,80,100</b> |

Note:

- (i)  $E = \sqrt{P * R}$  or Max. Working Voltage whichever is lower.
- (ii) E : Working Voltage(V) , P : Rated Power (W) , R : Resistance Value(Ω)
- (iii) Please keep the surface temperature do not exceed 105°C when operating.
- (iv) \* : Related number are depend on specific items only.
- (v) \*\* : TCR Hot (+25~+155°C). \*\*\* : ±0.5% available items with underline. Ex. 10
- (vi) R-value might be variance depend on soldering conditions and please consider this influence before use milli-ohm resistors, and strongly suggest use the recommend solder pad to design your circuits.
- (vii) Max. working & Max. overload current details please refer Annex. 1.

Table C. Metal Jumper

| Rating<br>Type & PN                  | Max. Working Current | Max. Overload Current | Resistance        |
|--------------------------------------|----------------------|-----------------------|-------------------|
| FMF06 1206<br><b>FMF06JTH000 -LH</b> | <b>80A</b>           | <b>100A</b>           | <b>Max. 0.2mΩ</b> |
| FMF25 2512<br><b>FMF25JPJ000 -LH</b> | <b>120A</b>          | <b>150A</b>           | <b>Max. 0.1mΩ</b> |

※Temperature Coefficient Resistance not applicable.

## 6. Part Number

| Type       | Size            | Tolerance       | Packing                | Watt       | Value       | TCR                | Special Code                              |
|------------|-----------------|-----------------|------------------------|------------|-------------|--------------------|-------------------------------------------|
| <b>FMF</b> | <b>06</b> :1206 | <b>D</b> :±0.5% | <b>T</b> :Paper Tape   | <b>F</b> : | <b>XXXX</b> | <b>:</b> :         | General                                   |
|            | <b>25</b> :2512 | <b>F</b> :±1%   | 4Kpcs (For 1206)       | 1/2W       | 4 digits    | As Rating table    | Standard <b>LH</b><br>Low EMF <b>BH</b>   |
|            |                 | <b>G</b> :±2%   | <b>P</b> :Plastic Tape | <b>H</b> : | Jumper      | <b>X</b> : Use for | AEC-Q200                                  |
|            |                 | <b>J</b> :±5%   | 4Kpcs (For 2512)       | 1W         | <b>000_</b> | 2512 ≤ 3mΩ         | &                                         |
|            |                 |                 |                        | 2W         | _ means     |                    | Anti-Sulfur                               |
|            |                 |                 |                        | <b>K</b> : | blank       |                    | Standard <b>LHM</b><br>Low EMF <b>BHM</b> |
|            |                 |                 |                        | 3W         |             |                    |                                           |

※ Anti-sulfur criteria:  $\Delta R \leq 1\%$ .

ASTM B-809, 90°C, 1000H & EIA-977, 105°C, 750H Compliant.

Example :

### FMF06FTHR001-BH

→ Metal strip, 1206 size, ±1%, paper tape, 1W, 1mΩ, low emf

### FMF25FPCR010-BHM

→ Metal strip, 2512 size, ±1%, plastic tape, 3W, 10mΩ, low emf, AEC-Q200

### FMF25FPCR003XBH

→ Metal strip, 2512 size, ±1%, plastic tape, 3W, 3mΩ, low emf, General

### FMF25FPCR2L5XBHM

→ Metal strip, 2512 size, ±1%, plastic tape, 3W, 2.5mΩ, low emf, AEC-Q200

## 7. Marking/Soldering Reference

### FMF 1206/2512

TOP : Marking. (4 Digits marking to identify the resistance value.)

“R005”=5mΩ

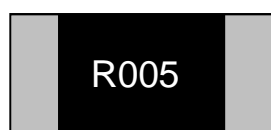

2512 “R001”=1mΩ



1206 “1”=1mΩ

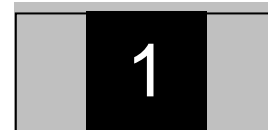

### Remarks.

2512 “L50”=0.5mΩ    2512“L75”=0.75 mΩ    2512“2L50”=2.5 mΩ

**Soldering Reference : Applicable for most industrial soldering request.**

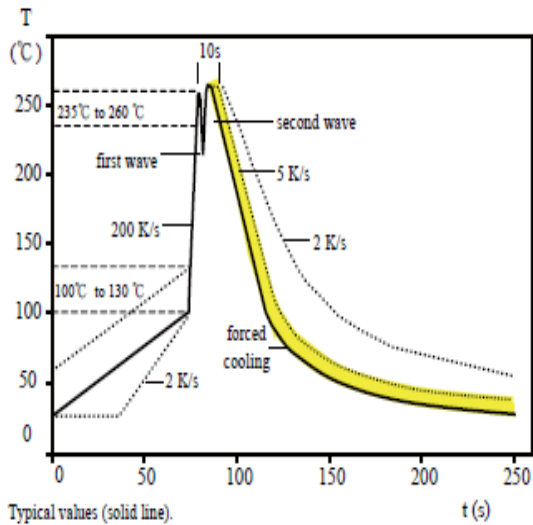

Typical values (solid line).  
Process limits (dotted line). **WAVE soldering.**

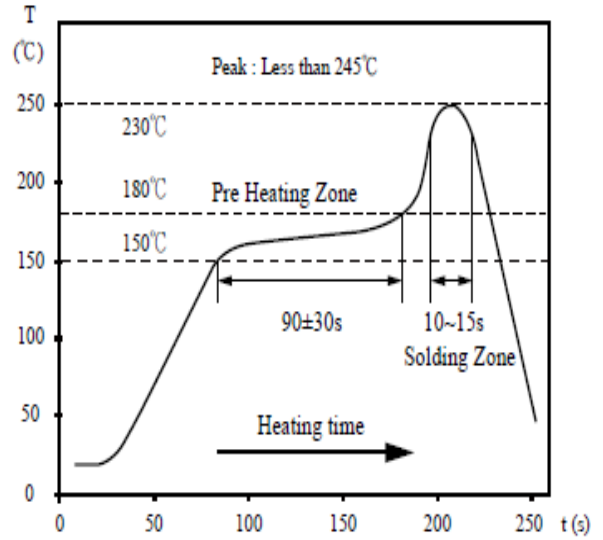

**IR Reflow soldering.**

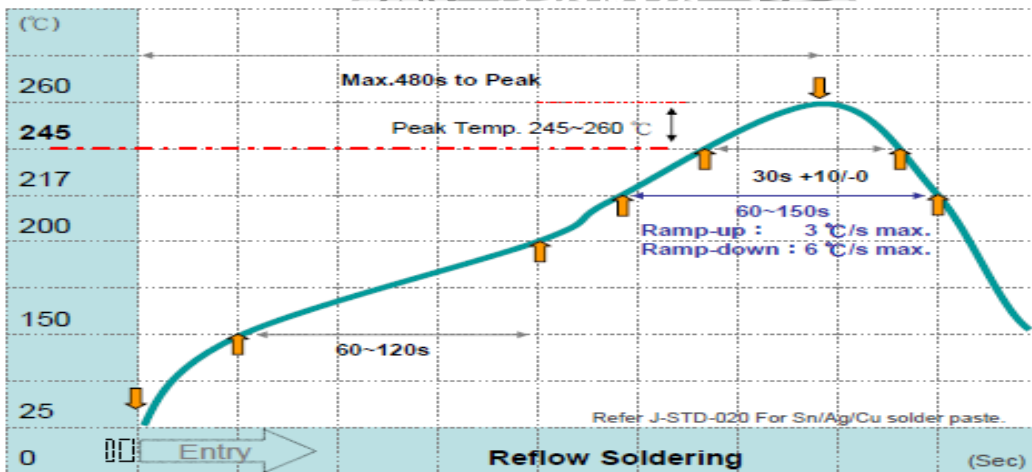

**Recommend Solder Pad Dimensions : unit.(mm)**

| Type                 | W    | D    | L    |
|----------------------|------|------|------|
| <b>1206</b>          | 1.80 | 1.30 | 4.70 |
| <b>1206 1~2 mR</b>   | 1.80 | 2.30 | 5.60 |
| <b>2512</b>          | 3.70 | 1.60 | 7.60 |
| <b>2512 0.5~3 mR</b> | 4.00 | 3.00 | 7.30 |

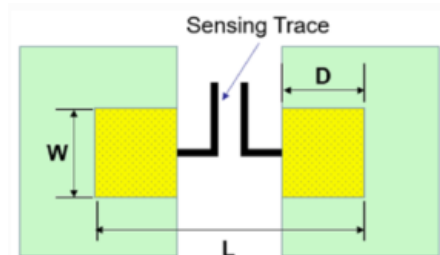

## 8. Reliability Performance

### 8.1 AEC-Q200 type.

| Test Item                                  | Specification                                                                             | Test Method<br>(AEC-Q200. IEC 60115)                                                                                                                                                                                                                                                                      |
|--------------------------------------------|-------------------------------------------------------------------------------------------|-----------------------------------------------------------------------------------------------------------------------------------------------------------------------------------------------------------------------------------------------------------------------------------------------------------|
| <b>DC Resistance</b>                       | J : $\pm 5\%$ G : $\pm 2\%$<br>F : $\pm 1\%$ D : $\pm 0.5\%$                              | <b>AEC-Q200 TABLE 7.1</b><br>IEC 60115-1 / JIS C 5201-1 , <b>Clause 4.5</b> Measure the resistance Value.                                                                                                                                                                                                 |
| <b>High Temperature Exposure (Storage)</b> | J、G : $\Delta R \leq \pm 3\%$<br>F、D : $\Delta R \leq \pm 1\%$                            | <b>AEC-Q200 TABLE 7.3</b><br>1000 hrs. @ T=170°C. Unpowered.<br>Measurement at 24 $\pm 2$ hours after test conclusion.                                                                                                                                                                                    |
| <b>Temperature Cycling</b>                 | J、G : $\Delta R \leq \pm 1\%$<br>F、D : $\Delta R \leq \pm 0.5\%$<br>No mechanical damage. | <b>AEC-Q200 TABLE 7.4</b><br>1000 Cycles (-55°C to +125°C). Measurement at 24 $\pm 2$ hours after test conclusion.<br><b>IEC 60115-1 Clause 4.19 for General Type</b><br>Repeat 5 cycles as follows -55°C (30min.) $\rightarrow$ 25°C (2~3min.) $\rightarrow$ 155°C (30min.) $\rightarrow$ 25°C (2~3min.) |
| <b>Moisture Resistance</b>                 | J、G : $\Delta R \leq \pm 1\%$<br>F、D : $\Delta R \leq \pm 0.5\%$                          | <b>AEC-Q200 TABLE 7.6</b><br>Test 65°C/80~100%RH/10Cycles.<br>Measurement at 24 $\pm 2$ hours after test conclusion.<br>(t=24hrs/cycle).                                                                                                                                                                  |
| <b>Biased Humidity</b>                     | J、G : $\Delta R \leq \pm 3\%$<br>F、D : $\Delta R \leq \pm 1\%$                            | <b>AEC-Q200 TABLE 7.7</b><br>1000 hours 85°C/85%RH.<br>10% of operating power.<br>Measurement at 24 $\pm 2$ hours after test conclusion.                                                                                                                                                                  |
| <b>Operational Life</b>                    | J、G : $\Delta R \leq \pm 3\%$<br>F、D : $\Delta R \leq \pm 1\%$                            | <b>AEC-Q200 TABLE 7.8</b><br>Test 1000hr @ T=125°C at specified rated power.<br>Measurement at 24 $\pm 2$ hours after test conclusion.                                                                                                                                                                    |
| <b>External Visual</b>                     | No visual damage and refer PDC marking code.                                              | <b>AEC-Q200 TABLE 7.9</b><br>Inspect device construction, marking and workmanship.                                                                                                                                                                                                                        |
| <b>Physical Dimension</b>                  | Within the spec.                                                                          | <b>AEC-Q200 TABLE 7.10</b><br>Verify physical dimensions to the applicable device detail specification.                                                                                                                                                                                                   |



|                                  |                                                                                           |                                                                                                                                   |
|----------------------------------|-------------------------------------------------------------------------------------------|-----------------------------------------------------------------------------------------------------------------------------------|
| <b>Mechanical Shock</b>          | Within product specification tolerance and no visible damage.                             | <b>AEC-Q200 TABLE 7.13</b><br>Test Peak value:100g's,Wave:Hail-sine, Duration:6ms,Velocity:12.3ft/sec.                            |
| <b>Vibration</b>                 | No mechanical damage.                                                                     | <b>AEC-Q200 TABLE 7.14</b><br>5 g's for 20 min., 12 cycles each of 3 orientations. Test from 10-2000 Hz.                          |
| <b>Resistance to Solder Heat</b> | J、G : $\Delta R \leq \pm 1\%$<br>F、D : $\Delta R \leq \pm 0.5\%$<br>No mechanical damage. | <b>AEC-Q200 TABLE 7.15</b><br>Solder dipping @ 270°C±5°C for 10sec.±1sec.                                                         |
| <b>Thermal Shock</b>             | J、G : $\Delta R \leq \pm 1\%$<br>F、D : $\Delta R \leq \pm 0.5\%$<br>No mechanical damage. | <b>AEC-Q200 TABLE 7.16</b><br>-55 to 155°C/ dwell time 15min/ Max transfer time 20sec/ 300cycles.                                 |
| <b>ESD</b>                       | $\Delta R \leq \pm 1\%$<br>No mechanical damage.                                          | <b>AEC-Q200-002</b><br>Test contact min. 1KV.                                                                                     |
| <b>Solder Ability</b>            | Over 95% of termination must be covered with solder.                                      | <b>AEC-Q200 TABLE 7.18</b><br>a)Baking 155°C 4H, dipping 235°C 5s<br>b)Steam 1H, dipping 215°C 5s<br>c)Steam 1H, dipping 260°C 7s |
| <b>Flammability</b>              | Refer UL-94.                                                                              | <b>AEC-Q200 TABLE 7.20</b><br>UL-94 V-0 or V-1 are acceptable                                                                     |
| <b>Board Flex</b>                | J、G : $\Delta R \leq \pm 1\%$<br>F、D : $\Delta R \leq \pm 0.5\%$<br>No mechanical damage. | <b>AEC-Q200 TABLE 7.21</b><br>Bending 2mm 2512.1206                                                                               |
| <b>Terminal Strength</b>         | No mechanical damage                                                                      | <b>AEC-Q200 TABLE 7.22</b><br>Force 1 Kg for 60 seconds.                                                                          |
| <b>Anti-Sulfur</b>               | $\Delta R \leq \pm 1\%$                                                                   | <b>ASTM-B-809-95(Modified)</b><br>Sulfur 1000 hours, 90±2°C<br><b>EIA-977(Test B)</b><br>Sulfur 750 hours, 105±2°C                |

Remarks 1. AEC-Q200 type compliable standard type reliability items.

Remarks 2. Jumper(0Ω) resistance specification according to Table C.

8.2 Standard type.

| Test Item                                          | Specification                                                                             | Test Method<br>(IEC 60115 / JIS C 5201-1)                                                                                                                                                                                                                                          |
|----------------------------------------------------|-------------------------------------------------------------------------------------------|------------------------------------------------------------------------------------------------------------------------------------------------------------------------------------------------------------------------------------------------------------------------------------|
| <b>DC Resistance</b>                               | J : $\pm 5\%$ G : $\pm 2\%$<br>F : $\pm 1\%$ D : $\pm 0.5\%$                              | <b>IEC 60115-1 / JIS C 5201-1 , Clause 4.5</b><br>Measure the resistance Value.                                                                                                                                                                                                    |
| <b>Short Time Overload</b>                         | J、G : $\Delta R \leq \pm 2\%$<br>F、D : $\Delta R \leq \pm 1\%$                            | <b>IEC 60115-1 / JIS C 5201-1 , Clause 4.13</b><br>5 x Rated power for 5 seconds<br>Measure resistance after 30 minutes                                                                                                                                                            |
| <b>Solderability</b>                               | Over 95% of termination must be covered with Solder                                       | <b>IEC 60115-1 / JIS C 5201-1 , Clause 4.17</b><br>After immersing flux, dip in the $235 \pm 2^\circ\text{C}$ molten solder bath for $3 \pm 0.5$ sec.                                                                                                                              |
| <b>Resistance to Solder Heat</b>                   | $\Delta R \leq \pm(1\% + 0.1\text{m}\Omega)$<br>No mechanical damage                      | <b>IEC 60115-1/JIS C 5201-1 , Clause 4.18</b><br>With $260 \pm 5^\circ\text{C}$ for $10 \pm 1$ sec.                                                                                                                                                                                |
| <b>Temperature Cycle</b>                           | J、G : $\Delta R \leq \pm 1\%$<br>F、D : $\Delta R \leq \pm 0.5\%$<br>No mechanical damage. | <b>IEC 60115-1/JIS C 5201-1 Clause 4.19</b><br>Repeat 5 cycles as follows $-55^\circ\text{C}$ (30min.) $\rightarrow 25^\circ\text{C}$ (2~3min.) $\rightarrow 155^\circ\text{C}$ (30min.) $\rightarrow 25^\circ\text{C}$ (2~3min.)                                                  |
| <b>Load Life Humidity</b>                          | J、G : $\Delta R \leq \pm 3\%$<br>F、D : $\Delta R \leq \pm 1\%$                            | <b>IEC 60115-1 / JIS C 5201-1 , Clause 4.24</b><br>$40 \pm 2^\circ\text{C}$ with relative humidity 90% ~ 95%<br>DC rated voltage for 1.5 hours On 30 minutes Off. Cycle repeated 1000 hours.<br>(Not applicable if 3W R value $< 1\text{m}\Omega$ )                                |
| <b>Temperature Coefficient of Resistance (TCR)</b> | Refer Rating Table.                                                                       | <b>IEC 60115-1, Clause 4.8</b><br>Temperature : (T1. $+25^\circ\text{C}$ ) ~ (T2. $+155^\circ\text{C}$ )<br>$\text{TCR}(\text{ppm}/^\circ\text{C}) = (R_2 - R_1) / R_1 \times 1 / (T_2 - T_1) \times 10^6$<br>( $+25^\circ\text{C}$ ~ $-55^\circ\text{C}$ please contact factory.) |
| <b>Load Life</b>                                   | J、G : $\Delta R \leq \pm 3\%$<br>F、D : $\Delta R \leq \pm 1\%$                            | <b>IEC 60115-1, Clause 4.25</b><br>Rated voltage for 1.5 hours then a pause 0.5 hours at $T = 70 \pm 2^\circ\text{C}$ . Cycle repeated 1000 hours.                                                                                                                                 |
| <b>Insulation Resistance</b>                       | Between termination and coating must over $1000\text{M}\Omega$                            | <b>IEC 60115-1, Clause 4.6</b><br>Test voltage : $100 \pm 15\text{V}$                                                                                                                                                                                                              |
| <b>Bending strength</b>                            | J、G : $\Delta R \leq \pm 1\%$<br>F、D : $\Delta R \leq \pm 0.5\%$<br>No mechanical damage. | <b>IEC 60115-1 / JIS C 5201-1 , Clause 4.33</b><br>Resistance change after bended on the 90mm PCB. Bending : 2mm                                                                                                                                                                   |

Remarks 1. Jumper(0 $\Omega$ ) resistance specification according to Table C.

## 9. PACKAGING

### 9.1 Peel Strength of Top Cover Tape

The peel speed shall be about 300 mm/min

The peel force of top cover tape shall be between 0.1 to 0.7N

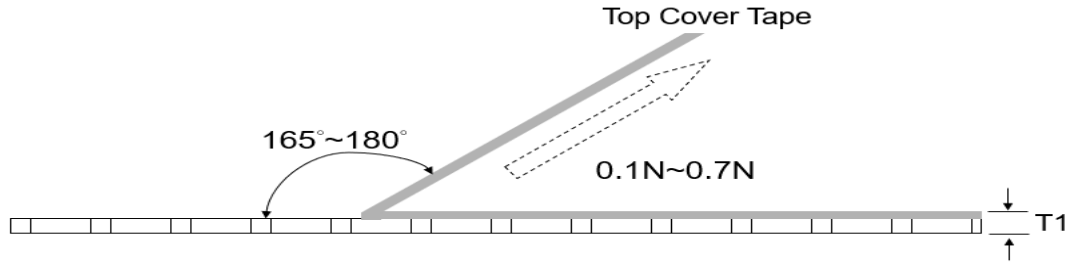

### 9.2 Tape Packaging Dimensions

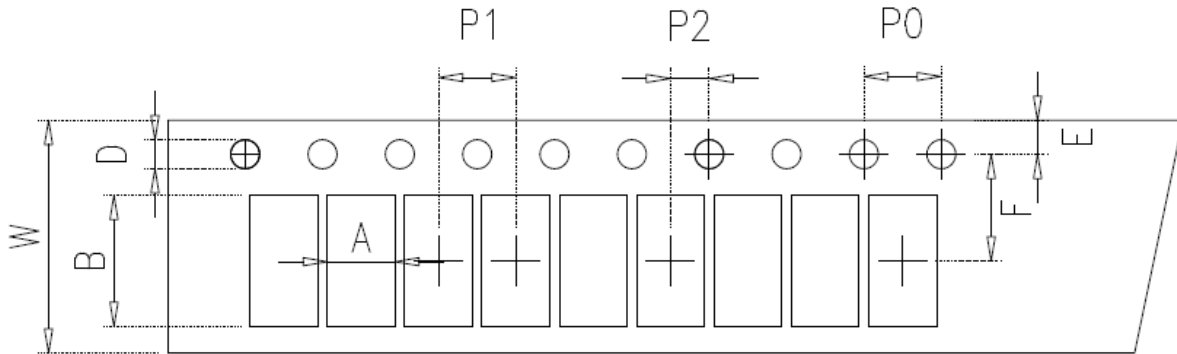

| Size | A         | B         | W         | F         | E         | P1        | P2        | P0        | D         | T1        |
|------|-----------|-----------|-----------|-----------|-----------|-----------|-----------|-----------|-----------|-----------|
| 1206 | 2.00±0.20 | 3.60±0.20 | 8.00±0.30 | 3.50±0.05 | 1.75±0.10 | 4.00±0.10 | 2.00±0.05 | 4.00±0.10 | 1.50±0.10 | 1.00±0.10 |
| 2512 | 3.50±0.20 | 6.75±0.20 | 12.0±0.30 | 5.50±0.05 | 1.75±0.10 | 4.00±0.10 | 2.00±0.05 | 4.00±0.10 | 1.50±0.10 | 1.15±0.10 |

### 9.3 Reel Dimensions

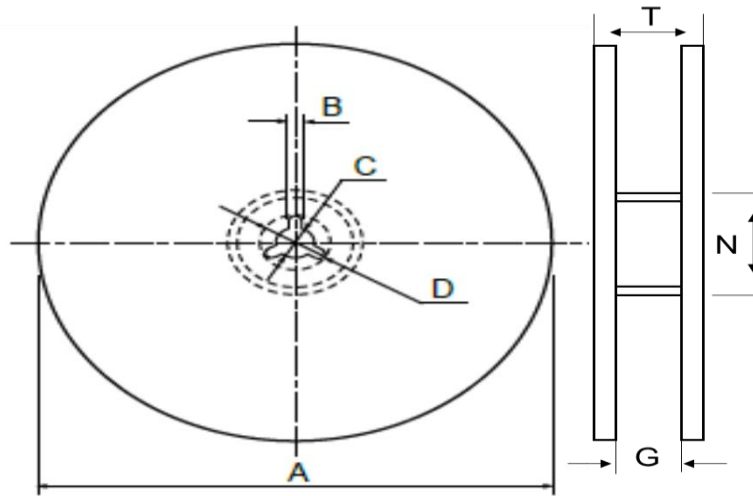

| Size | Packaging Q'ty | A         | N        | C        | D        | B       | G        | T        |
|------|----------------|-----------|----------|----------|----------|---------|----------|----------|
| 1206 | 4kpcs/Reel     | 178.0±2.0 | 60.0±0.5 | 13.0±0.5 | 20(Min.) | 2.0±0.5 | 10.0±1.5 | 14.9max. |
| 2512 | 4kpcs/Reel     | 178.0±2.0 | 60.0±0.5 | 13.0±0.5 | 20(Min.) | 2.0±0.5 | 13.8±1.5 | 16.7max. |

### 10. Storage & Handling

... Products are recommended to be used up within one year as ensured shelf life.

Check solder ability in case shelf life extension is needed.

... To store products with following condition:

Temperature: 5 to 40°C ; Humidity: 20 to 70% relative humidity.

#### Precaution for use :

The AEC-Q200 series resistors is mainly used on general automotive equipment without safety considerations.

Please contact our company in advanced if you intend to use resistor for designing the equipment which may

damage itself and the safety of third party. If necessary, please consider to add the protect circuit in devising

process and obtaining fully safety evaluation. The contents of the acknowledgment is only used for our parent

company, marketing subsidiaries and official marketing agents who purchase our products. Not applicable for the

other nonofficial channels.

※ All products specification and data are subject to change without notice.

**Annex.1** Max. working & Max. overload current

| 2512 Rating Power 1.0W |                  |                   | 2512 Rating Power 2.0W |                  |                   |
|------------------------|------------------|-------------------|------------------------|------------------|-------------------|
| R_Value (mΩ)           | Max. Working (A) | Max. Overload (A) | R_Value (mΩ)           | Max. Working (A) | Max. Overload (A) |
| 1                      | 31.6             | 70.7              | 1                      | 44.7             | 100.0             |
| 2                      | 22.4             | 50.0              | 2                      | 31.6             | 70.7              |
| 2.5                    | 20.0             | 44.7              | 2.5                    | 28.3             | 63.2              |
| 3                      | 18.3             | 40.8              | 3                      | 25.8             | 57.7              |
| 4                      | 15.8             | 35.4              | 4                      | 22.4             | 50.0              |
| 5                      | 14.1             | 31.6              | 5                      | 20.0             | 44.7              |
| 6                      | 12.9             | 28.9              | 6                      | 18.3             | 40.8              |
| 7                      | 12.0             | 26.7              | 7                      | 16.9             | 37.8              |
| 8                      | 11.2             | 25.0              | 8                      | 15.8             | 35.4              |
| 9                      | 10.5             | 23.6              | 9                      | 14.9             | 33.3              |
| 10                     | 10.0             | 22.4              | 10                     | 14.1             | 31.6              |
| 12                     | 9.1              | 20.4              | 12                     | 12.9             | 28.9              |
| 15                     | 8.2              | 18.3              | 15                     | 11.5             | 25.8              |
| 18                     | 7.5              | 16.7              | 18                     | 10.5             | 23.6              |
| 20                     | 7.1              | 15.8              | 20                     | 10.0             | 22.4              |
| 22                     | 6.7              | 15.1              | 22                     | 9.5              | 21.3              |
| 25                     | 6.3              | 14.1              | 25                     | 8.9              | 20.0              |
| 30                     | 5.8              | 12.9              | 30                     | 8.2              | 18.3              |
| 33                     | 5.5              | 12.3              | 33                     | 7.8              | 17.4              |
| 35                     | 5.3              | 12.0              | 35                     | 7.6              | 16.9              |
| 40                     | 5.0              | 11.2              | 40                     | 7.1              | 15.8              |
| 50                     | 4.5              | 10.0              | 50                     | 6.3              | 14.1              |
| 60                     | 4.1              | 9.1               | 60                     | 5.8              | 12.9              |
| 70                     | 3.8              | 8.5               | 70                     | 5.3              | 12.0              |
| 75                     | 3.7              | 8.2               | 75                     | 5.2              | 11.5              |
| 80                     | 3.5              | 7.9               | 80                     | 5.0              | 11.2              |
| 100                    | 3.2              | 7.1               | 100                    | 4.5              | 10.0              |
|                        |                  |                   | 150                    | 3.7              | 8.2               |

| 2512 Rating Power 3.0W |                  |                   |
|------------------------|------------------|-------------------|
| R_Value (mΩ)           | Max. Working (A) | Max. Overload (A) |
| 0.5                    | 77.5             | 173.2             |
| 0.75                   | 63.2             | 141.4             |
| 1                      | 54.8             | 122.5             |
| 2                      | 38.7             | 86.6              |
| 2.5                    | 34.6             | 77.5              |
| 3                      | 31.6             | 70.7              |
| 4                      | 27.4             | 61.2              |
| 5                      | 24.5             | 54.8              |
| 6                      | 22.4             | 50.0              |
| 7                      | 20.7             | 46.3              |
| 8                      | 19.4             | 43.3              |
| 9                      | 18.3             | 40.8              |
| 10                     | 17.3             | 38.7              |
| 12                     | 15.8             | 35.4              |
| 14                     | 14.6             | 32.7              |
| 15                     | 14.1             | 31.6              |
| 16                     | 13.7             | 30.6              |
| 18                     | 12.9             | 28.9              |
| 20                     | 12.2             | 27.4              |
| 25                     | 11.0             | 24.5              |
| 30                     | 10.0             | 22.4              |
| 33                     | 9.5              | 21.3              |
| 35                     | 9.3              | 20.7              |
| 40                     | 8.7              | 19.4              |
| 50                     | 7.7              | 17.3              |
| 60                     | 7.1              | 15.8              |
| 75                     | 6.3              | 14.1              |
| 80                     | 6.1              | 13.7              |
| 100                    | 5.5              | 12.2              |

| 1206 Rating Power 0.5W |                  |                   | 1206 Rating Power 1.0W |                  |                   |
|------------------------|------------------|-------------------|------------------------|------------------|-------------------|
| R_Value (mΩ)           | Max. Working (A) | Max. Overload (A) | R_Value (mΩ)           | Max. Working (A) | Max. Overload (A) |
| 1                      | 22.4             | 50.0              | 1                      | 31.6             | 70.7              |
| 2                      | 15.8             | 35.4              | 2                      | 22.4             | 50.0              |
| 3                      | 12.9             | 28.9              | 3                      | 18.3             | 40.8              |
| 4                      | 11.2             | 25.0              | 4                      | 15.8             | 35.4              |
| 5                      | 10.0             | 22.4              | 5                      | 14.1             | 31.6              |
| 6                      | 9.1              | 20.4              | 6                      | 12.9             | 28.9              |
| 7                      | 8.5              | 18.9              | 7                      | 12.0             | 26.7              |
| 8                      | 7.9              | 17.7              | 8                      | 11.2             | 25.0              |
| 9                      | 7.5              | 16.7              | 9                      | 10.5             | 23.6              |
| 10                     | 7.1              | 15.8              | 10                     | 10.0             | 22.4              |
| 12                     | 6.5              | 14.4              | 12                     | 9.1              | 20.4              |
| 15                     | 5.8              | 12.9              | 15                     | 8.2              | 18.3              |
| 18                     | 5.3              | 11.8              | 18                     | 7.5              | 16.7              |
| 20                     | 5.0              | 11.2              | 20                     | 7.1              | 15.8              |
| 25                     | 4.5              | 10.0              | 25                     | 6.3              | 14.1              |
| 30                     | 4.1              | 9.1               | 30                     | 5.8              | 12.9              |

