

信昌電子陶瓷股份有限公司

Prosperity Dielectrics Co., Ltd.

No.566-1, Gaoshi Rd., Lujhu, Yangmei Dist., Taoyuan City 32668, Taiwan, R.O.C.

Tel. : +886-3-4753355

Fax : +886-3-4854959

SPECIFICATION FOR APPROVAL

DATE :

CUSTOMER :

PART NAME :

Metal Strip Type Halogen Free Current Sensing Resistors

CUSTOMER'S DWG. NO. :

CUSTOMER'S PART NO. :

PDC PART NO. :

FME05 Series

DESCRIPTION. :

0805 Metal Strip Current Sensing Resistors

RESULT	ACTION	" V "	CUSTOMER'S SIGNATURE	NOTE
FULL APPROVED				
CONDITIONAL APPROVED				
REJECTED				

OUR ACTION	SIGNATURE
PREPARED By	Jenny Tseng
CHECKED By	Steven Wang
APPROVED By	Byron Tsai

CUSTOMER SIGNATURE FOR
ACCEPTANCE

Contents.

Descriptions	Pages
01. Features	2
02. Applications	2
03. Dimension and construction	2
04. Power Derating Curve	3
05. Rating	3
06. Part Number	4
07. Marking / Soldering	5
08. Reliability Performance	6-8
09. Packing Information	9-10
10. Storage / Handling	10

1. Features

- High power rating and low TCR.
- Low resistance and high precision (1%).
- Excellent reliability and suitable cost.
- Suitable for lead free soldering.
- High precision trimming implement.
- RoHS compliant & Halogen Free.

2. Applications

- Switching model power supply.
- Battery pack.
- Notebook, Tablet PC
- Test Instrument.
- Power Amplifier.

3. Dimension and Construction

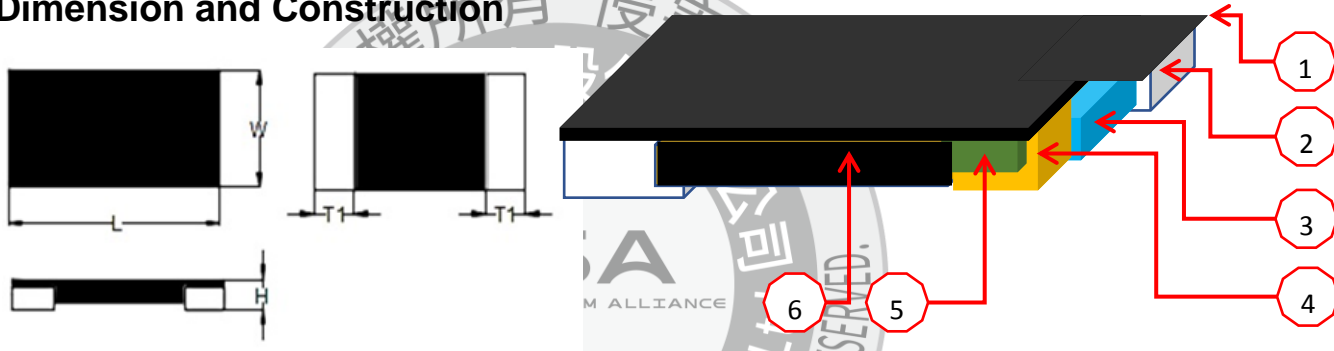

Item	1	2	3	4	5	6
Construction	Protective Coating	outer Terminal	Middle Terminal	Inner Terminal	Resistive Element	Protective Coating
Material	Epoxy Resin Substrate	Matte Sn	Nickle	Copper	Manganin Alloy	Epoxy Resin

Unit : mm

Type	Type of Terminal	Power Rating (W)	Resistance Range (mΩ)	Dimensions(mm)			
				L	W	H	T1
0805	2	1/2 1	0	2.03±0.20	1.27±0.20	0.45±0.15	0.40±0.15
			1.5~2				0.50±0.15
			3				
			4				
			5~6				
			7~10			0.40±0.15	0.40±0.15
			15~20				

4. Power Derating Curve

Operating Temperature Range: -55 to +155°C

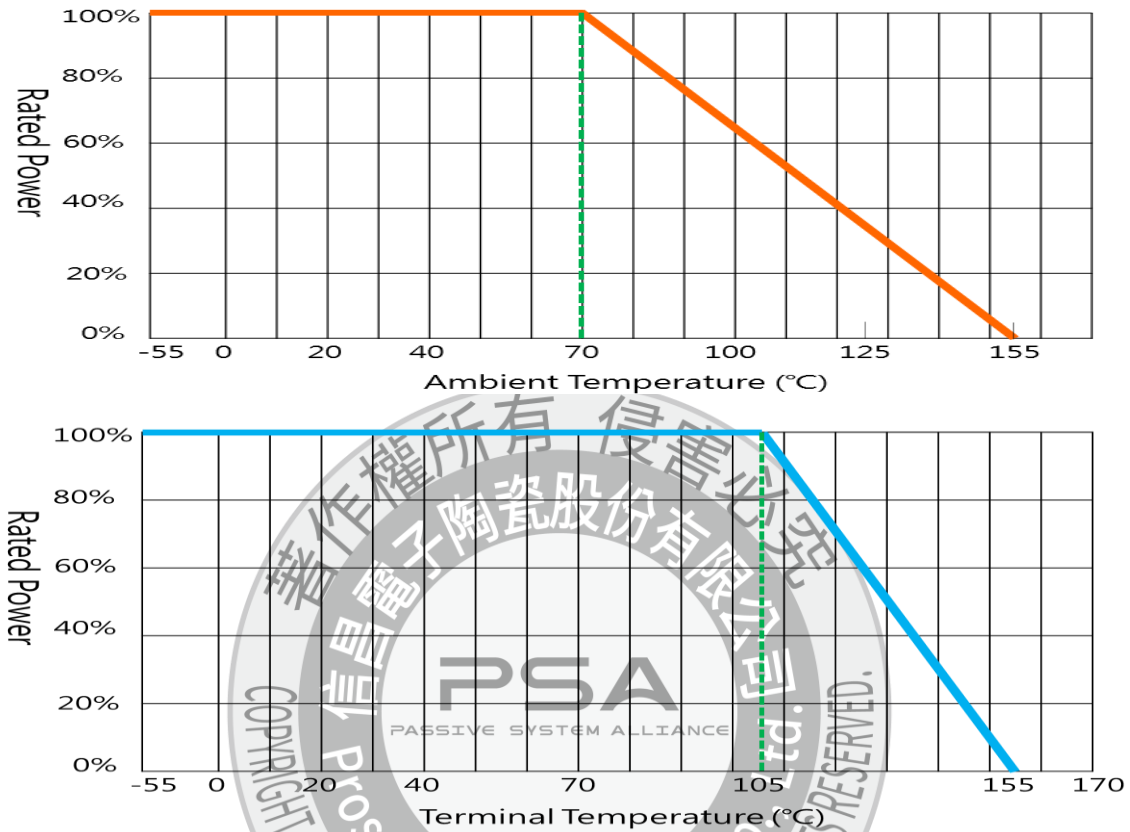

5. Rating

Table A.

Rating Type	Type of Terminal	Tolerance (%)	Rating 70°C (W)	Max. Working Current*	Max. Overload Current*	Alloy Type	Temperature coefficient of Resistance (ppm/°C)**	Resistance (mΩ) ***
FME05 (0805)	2	±1%(F) ±2%(G) ±5%(J)	1/2	18.26A	40.82A	Low EMF	±100	1.5
				15.81A	35.36A		±70	2
				12.91A	26.87A		±50	3~10
				5.77A	12.91A		±50	15~20
			1	25.82A	57.74A	Low EMF	±100	1.5
				22.36A	50.00A		±70	2
				18.26A	40.82A		±50	3~10
				8.16A	18.26A		±50	15~20

Note:

- (i) $I = \sqrt{P/R}$ or Max. Working Current.
- (ii) I : Working Current(A) , P : Rated Power (W) , R : Resistance Value(Ω)
- (iii) Please keep the terminal temperature do not exceed 105°C when working.
- (iv) * : Related number are depend on specific items only. ** : TCR Hot (+25~+155°C).
- (v) *** : R-value might be variance depend on soldering conditions and please consider this influence before use milli-ohm resistors, and strongly suggest use the recommend solder pad to design your circuits.

Table B. Metal Jumper ※Temperature Coefficient Resistance not applicable.

Type	Rating	Type of Terminal	Max. Working Current	Max. Overload Current	Resistance
FME05 (0805)					
FME052JTF000 -LH		2	50A	100A	Max. 0.2 m Ω

6.Part Number

Type	Size	Terminal	Tolerance	Packing	Watt	Value	TCR	Special Code
FME	05 :0805	2 :2 terminals 4 :4 terminals	F :±1%	T:Paper	F :	RXXX	N :	General:
			G :±2%	Tape	1/2W	4 digit.	100 ppm	Low EMF
			J :±5%	5Kpcs	H :	RXLX	X :	BH
					1W	4 digit	P :	AEC-Q200:
							50 ppm	Low EMF
								BHM

Example :

FME052FTFR010PBH

→Metal strip, 0805 size, ±1%, paper tape, 1/2W, 10m Ω , low emf

FME052FTHR1L5NBH

→Metal strip, 0805 size, ±1%, paper tape, 1W, 1.5m Ω , low emf

FME052FTHR003PBHM

→Metal strip, 0805 size, ±1%, paper tape, 1W, 3m Ω , low emf, AEC-Q200

7. Marking / Soldering

FME052 No Marking.

Soldering Reference : Applicable for most industrial soldering request.

Compatible with reflow soldering. (Not compatible with wave soldering)

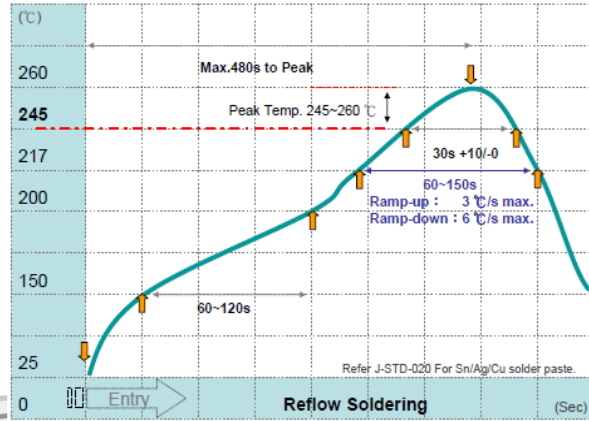
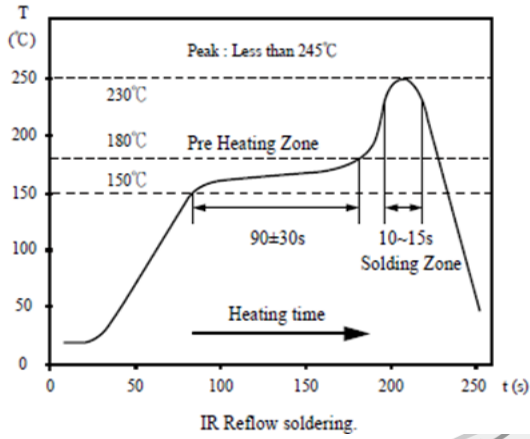

Recommend Solder Pad Dimensions : (Unit:mm)

Type	Resistance (mΩ)	W	D	L
0805	1.5~4	1.44	1.38	3.56
	0 5~20	1.44	1.18	3.56

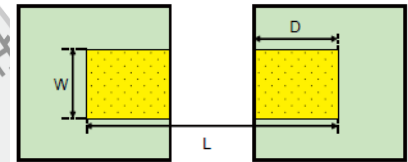

8. Reliability Performance (AEC-Q200)

* Normal test items for general product.

Test Item	Specification	Test Method (AEC-Q200. IEC 60115)
*DC Resistance	J : $\pm 5\%$ G : $\pm 2\%$ F : $\pm 1\%$	AEC-Q200 TABLE 7.1 IEC 60115-1 / JIS C 5201-1 , Clause 4.5 Measure the resistance Value.
High Temperature Exposure (Storage)	0 m Ω : ≤ 0.2 m Ω Others : $\Delta R \leq \pm 1\%$	AEC-Q200 TABLE 7.3 1000 hrs. @ T=155°C. Unpowered. Measurement at 24 ± 2 hours after test conclusion.
*Temperature Cycling	0 m Ω : ≤ 0.2 m Ω Others : $\Delta R \leq \pm 1\%$ No mechanical damage.	AEC-Q200 TABLE 7.4 1000 Cycles (-55°C to +125°C). Measurement at 24 ± 2 hours after test conclusion. IEC 60115-1 Clause 4.19 for General Type Repeat 5 cycles as follows -55°C (30min.) \rightarrow 25°C (2~3min.) \rightarrow 155°C (30min.) \rightarrow 25°C (2~3min.)
Moisture Resistance	0 m Ω : ≤ 0.2 m Ω Others : $\Delta R \leq \pm 1\%$	AEC-Q200 TABLE 7.6 Test 65°C/80~100%RH/10Cycles. Measurement at 24 ± 2 hours after test conclusion. (t=24hrs/cycle).
Biased Humidity	0 m Ω : ≤ 0.2 m Ω Others : $\Delta R \leq \pm 1\%$	AEC-Q200 TABLE 7.7 1000 hours 85°C/85%RH. 10% of operating power. Measurement at 24 ± 2 hours after test conclusion.
Operational Life	0 m Ω : ≤ 0.2 m Ω 1.5~6 m Ω : $\Delta R \leq \pm 1\%$ 7~20 m Ω : $\Delta R \leq \pm 2\%$	AEC-Q200 TABLE 7.8 Test 1000hr @ TA=125°C at specified rated power. Measurement at 24 ± 2 hours after test conclusion.
External Visual	No visual damage and refer PDC marking code.	AEC-Q200 TABLE 7.9 Inspect device construction, marking and workmanship.
Physical Dimension	Within the spec.	AEC-Q200 TABLE 7.10 Verify physical dimensions to the applicable device detail specification.

Mechanical Shock	Within product specification tolerance and no visible damage.	AEC-Q200 TABLE 7.13 Test Peak value:100g's,Wave:Hail-sine, Duration:6ms,Velocity:12.3ft/sec.
Vibration	0 mΩ : ≤ 0.2 mΩ Others : ΔR ≤ ±1% No mechanical damage.	AEC-Q200 TABLE 7.14 5 g's for 20 min., 12 cycles each of 3 orientations. Test from 10-2000 Hz.
*Resistance to Solder Heat	0 mΩ : ≤ 0.2 mΩ Others : ΔR ≤ ±1% No mechanical damage.	AEC-Q200 TABLE 7.15 Solder dipping @ 260°C±5°C for 10sec.±1sec.
Thermal Shock	0 mΩ : ≤ 0.2 mΩ Others : ΔR ≤ ±1% No mechanical damage.	AEC-Q200 TABLE 7.16 -55 to 155°C/ dwell time 15min/ Max transfer time 20sec/ 300cycles.
ESD	0 mΩ : ≤ 0.2 mΩ Others : ΔR ≤ ±1% No mechanical damage.	AEC-Q200-002 Test contact min. 1KV.
*Solder Ability	Over 95% of termination must be covered with solder.	AEC-Q200 TABLE 7.18 a) Baking 155°C 4H, dipping 235°C 5s b) Steam 8H, dipping 215°C 5s c) Steam 8H, dipping 260°C 7s IEC 60115-1, Clause 4.17 for General Type After immersing flux, dip in the 245±2°C molten solder bath for 3±0.5 sec.
Flammability	Refer UL-94.	AEC-Q200 TABLE 7.20 UL-94 V-0 or V-1 are acceptable
*Board Flex	0 mΩ : ≤ 0.2 mΩ Others : ΔR ≤ ±2% No mechanical damage.	AEC-Q200 TABLE 7.21 Bending 2mm for 60 seconds.
Anti-Sulfur	0 mΩ : ≤ 0.2 mΩ Others : ΔR ≤ ±1%	EIA-977(Test B) Sulfur 750 hours, 105±2°C

*Short Time Overload	0 mΩ : ≤ 0.2 mΩ Others : ΔR ≤ ±1%	IEC 60115-1, Clause 4.13 5 × Rated power for 5 seconds
*Load Life Humidity	0 mΩ : ≤ 0.2 mΩ 1.5~6 mΩ : ΔR ≤ ±1% 7~20 mΩ : ΔR ≤ ±2%	IEC 60115-1, Clause 4.24 40±2°C with relative humidity 90% ~ 95% D.C. rated voltage for 1.5 hours ON 30 minutes OFF. Cycle repeated 1000 hours.
*Temperature Coefficient of Resistance (TCR)	Within the spec.	IEC 60115-1, Clause 4.8 $T_1 \quad T_2$ Test temperature : 25°C~ +155°C $TCR(ppm/^{\circ}C) = (R_2 - R_1) / R_1 \times 1 / (T_2 - T_1) \times 10^6$ (+25~ -55°C please contact factory.)
*Load Life	0 mΩ : ≤ 0.2 mΩ 1.5~6 mΩ : ΔR ≤ ±1% 7~20 mΩ : ΔR ≤ ±2%	IEC 60115-1, Clause 4.25 Rated current for 1.5 hours for followed by a pause 0.5 hour at 70±2°C. Cycle repeated 1000 hours.
*Insulation Resistance	Between termination and coating must over 100MΩ	IEC 60115-1, Clause 4.6 Test voltage : 100±15V

9. PACKAGING

9.1 Peel Strength of Top Cover Tape

The peel speed shall be about 300 mm/min

The peel force of top cover tape shall be between 0.1 to 0.7N

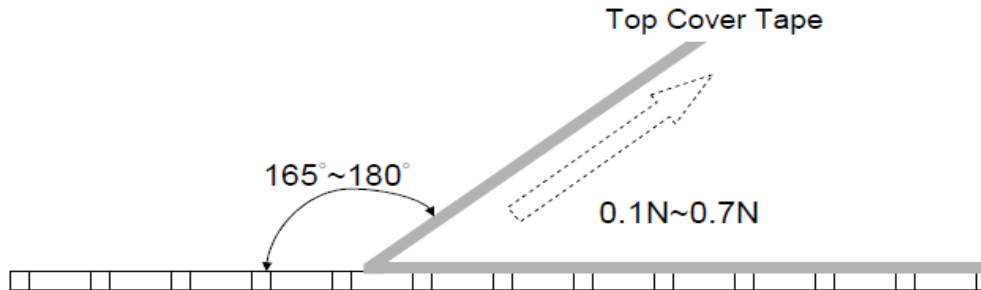

9.2 Tape Packaging Dimensions

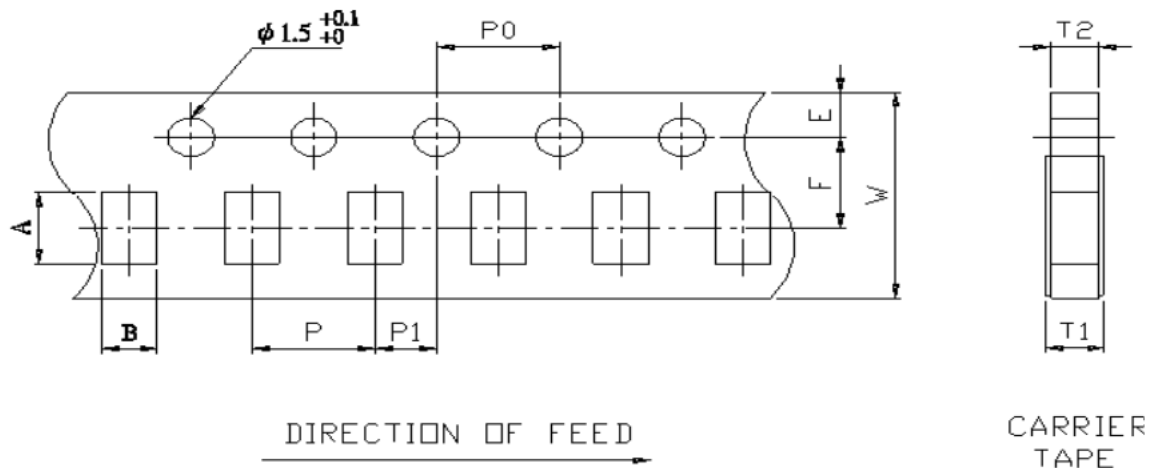

Size	Resistance Range(m Ω)	A	B	W	F	E	T1	T2	P	P1	P0	10*P0
0805	$\begin{matrix} 0 \\ 1.5 \sim 20 \end{matrix}$	2.40 ± 0.20	1.65 ± 0.20	8.0 ± 0.30	3.50 ± 0.05	1.75 ± 0.10	$0.60 \pm 0.2 / -0$	0.60 ± 0.05	4.00 ± 0.10	2.00 ± 0.05	4.00 ± 0.10	40.00 ± 0.20

unit : mm

9.3 Reel Dimensions

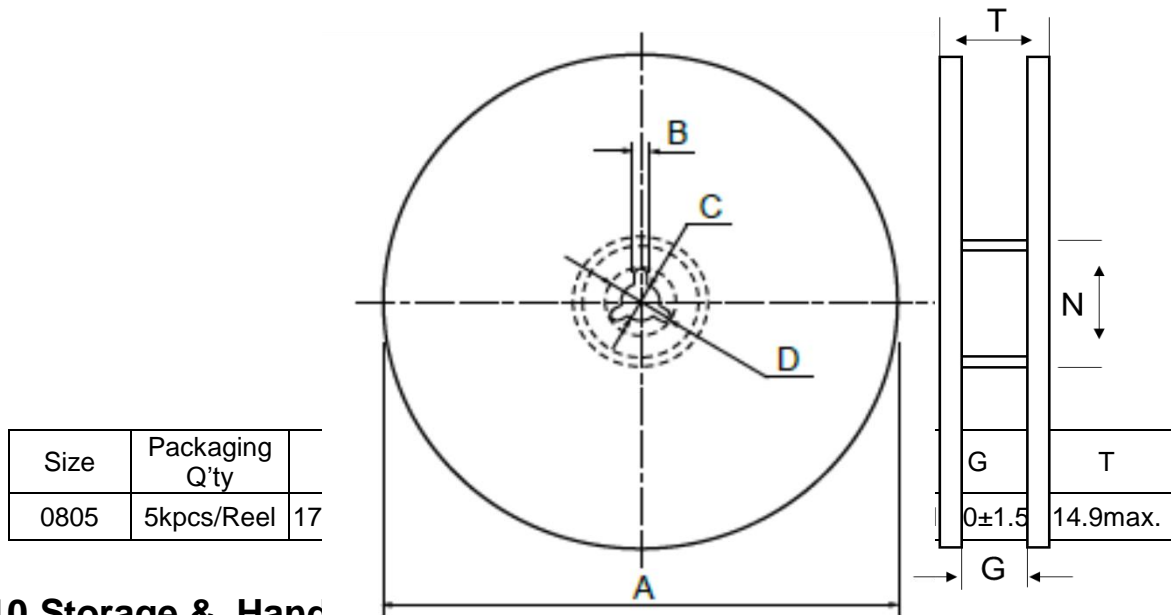

10.Storage & Hanc

- ... Products are recommended to be used up within one year as ensured shelf life.
- Check solder ability in case shelf life extension is needed.
- ... To store products with following condition:
Temperature:5 to 40°C ; Humidity: 20 to 70% relative humidity.

Precaution for use :

The AEC-Q200 series resistors is mainly used on general automotive equipment without safety considerations. Please contact our company in advanced if you intend to use resistor for designing the equipment which may damage itself and the safety of third party. If necessary, please consider to add the protect circuit in devising process and obtaining fully safety evaluation. The contents of the acknowledgment is only used for our parent company, marketing subsidiaries and official marketing agents who purchase our products. Not applicable for the other nonofficial channels.

※ All products specification and data are subject to change without notice.